

**DESIGNATED USE**

The rescue lifting device RUP 502-[...] series is a component of rescue system. Using this device the rescuer can lift the other person from a lower to higher place or lower him from a higher to lower place. Lowering distance is limited to 2 meters. The RUP 502-[...] series device complies with EN 1496:2006 / B.

Description of RUP 502-[...] series rescue lifting devices:

- RUP 502 - lifting device with grip for mounting on the tripods: TM 9 / TM 9-L / TM 9-W /
- RUP 502-A - lifting device with grip for mounting on the tripods: TM 6 / TM 12 / TM 12-2 / TM 13
- RUP 502-B - lifting device with grip for mounting on the tripods: TM 7

sign "xx" - standard working rope length in meters (20, 25m)

**TECHNICAL DATA**

Working load limit:	140 kg
hand force required:	22 kg
Gear ratio:	5:1
Crank length:	300 mm
Rope diameter:	∅ 6,3 mm
Weight:	rope 20 m - 13 kg rope 25 m - 14 kg

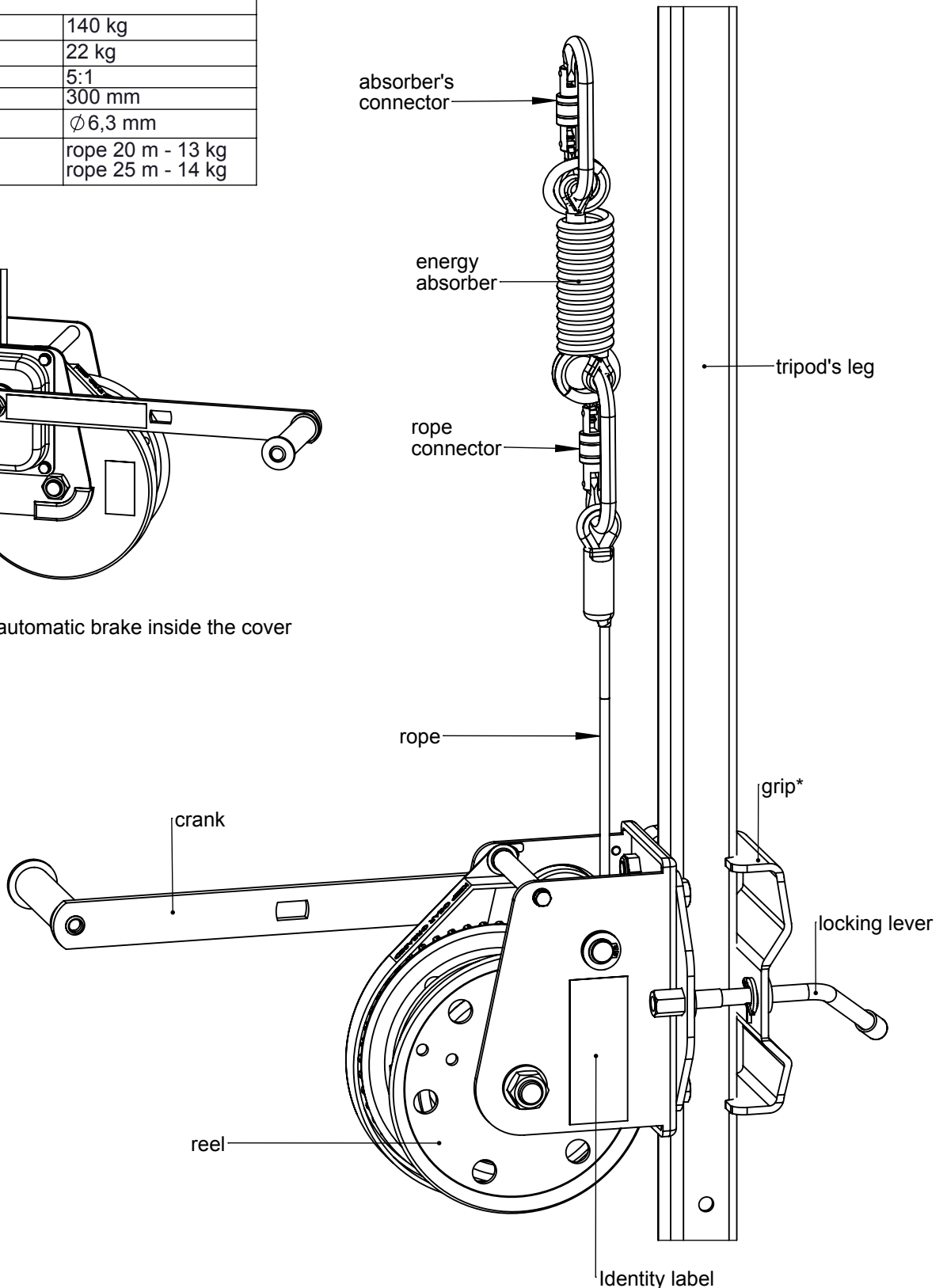
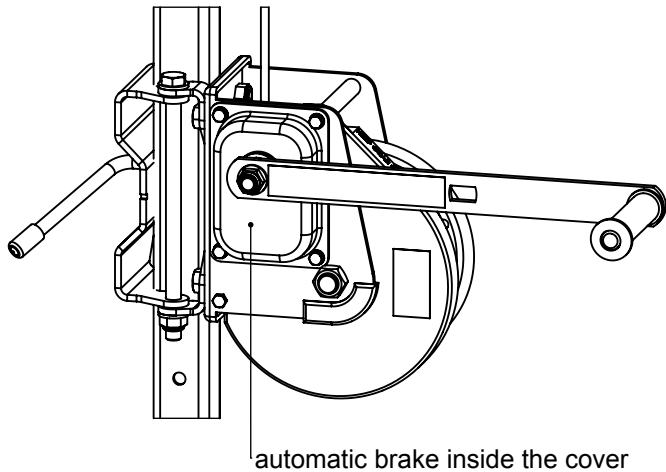

\* The grip shape may be different in particular RUP 502-[...] model variants.

# INSTALLING ON THE TRIPOD

1. Open the grip.

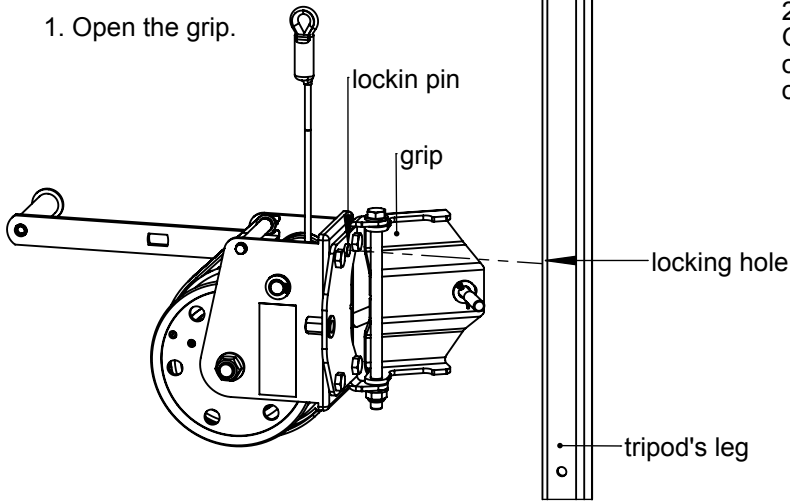

2. Put the device on the tripod's leg. Grip locking pin must be fastened on the locking hole situated on the outside part of the tripod's leg.

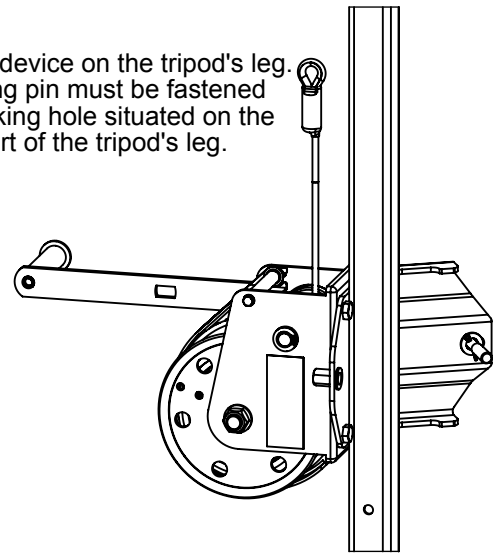

3. Close grip. Lock the grip using the lever. Grease the lever's thread with small amount of constant lubricant before installation. The winch shall not slide on the tripod's leg.

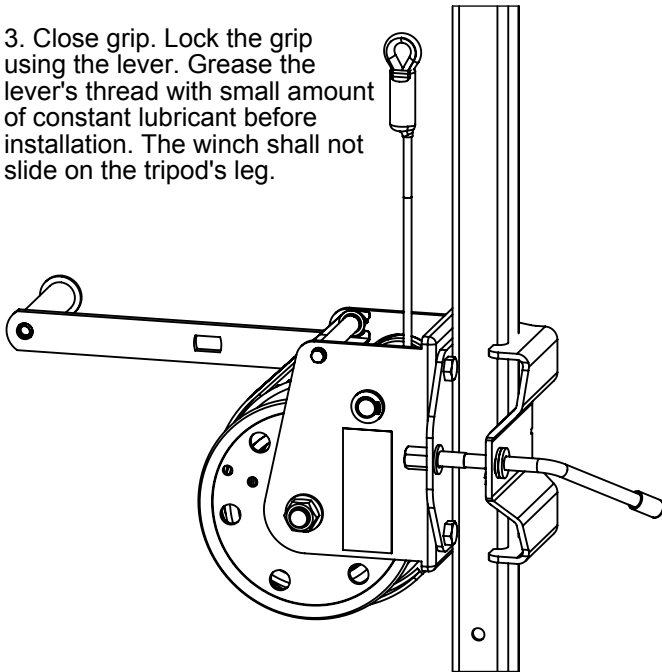

4. Guide the rope behind two bolts located above the reel.

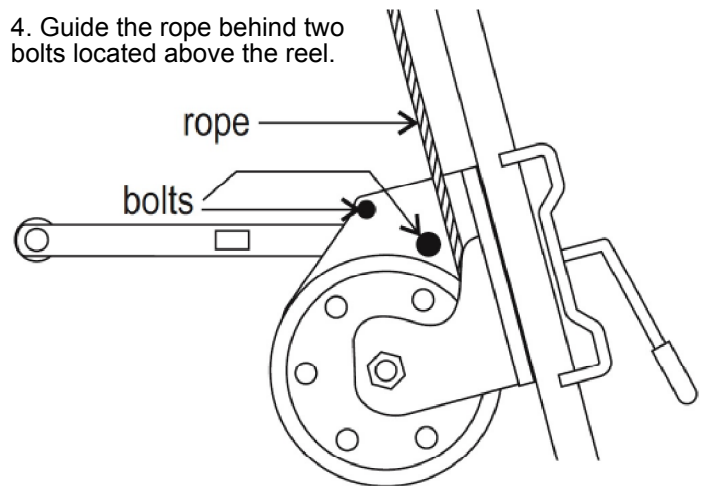

## CAUTION!

Ensure that locking pin is properly fitted into locking hole. Locking pin prevents against device sliding on the tripod's leg.

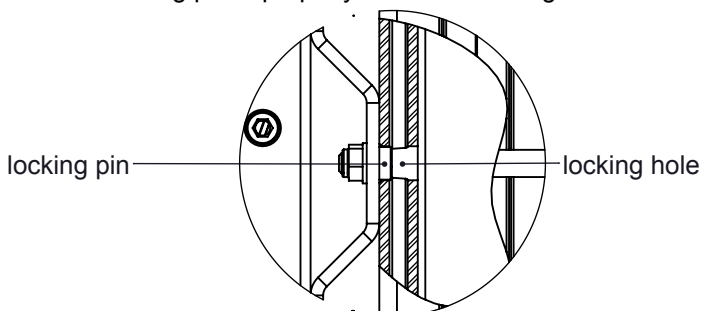

**CORRECT!**  
Locking pin mounted in the locking hole

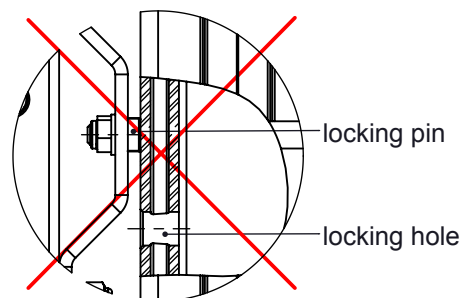

**WRONG!**  
Locking pin outside the locking hole

## INSTALLING DEVICE ON A STRUCTURAL ANCHOR ELEMENT

It is possible to install device directly on the structural anchor element like flat surface (e.g. wall) or steel profile. The structural anchor element to which the device is fastened must have stable construction and have minimal static strength of 14 kN. Construction and fastening of the structural anchor element must prevent of accidental disconnection of the device. To install device on the structural anchor element we must remove the grip which is designed to be used only with the tripod.

### REMOVING THE GRIP OF THE RUP 502 DEVICE

1. Unscrew four M10 nuts on the bolts fastened the grip to the winch in RUP 502 device.

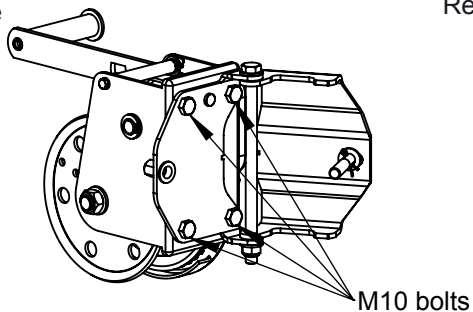

2. Remove the bolts. Remove the grip.

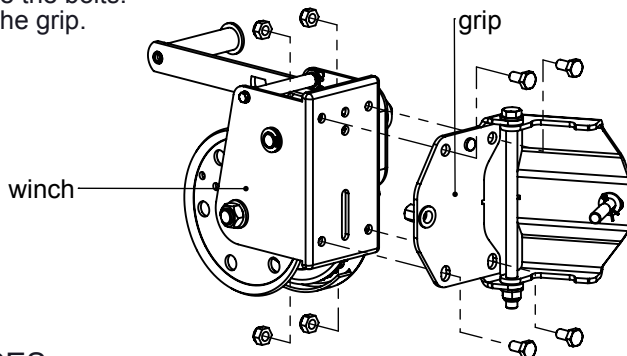

### REMOVING THE GRIP OF THE RUP 502-A / 502-B DEVICES

1. Unscrew two M10 nut fastening the grip to the winch of RUP 502-A / 502-B device.

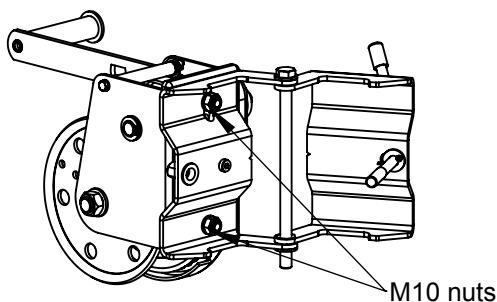

2. Remove the bolts. Remove the grip.

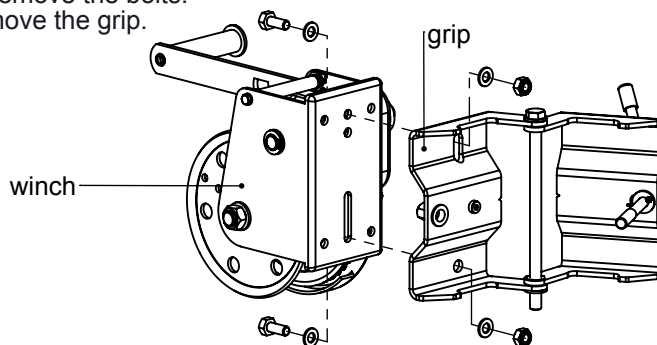

### INSTALLING ON THE FLAT SURFACE

1. Device should be installed using two holes ( $\varnothing 10$  mm and oblong  $\varnothing 10 \times 45$ ) situated on the back wall of the winch.
2. Install winch using two M10 steel mechanical or chemical anchor bolts. Anchors should be installed in accordance with the installation instructions provided by the manufacturer of the anchors.
3. Put the washer M10 (DIN 125A) under each nut. Tighten two M10 self-locking nuts (DIN 985).

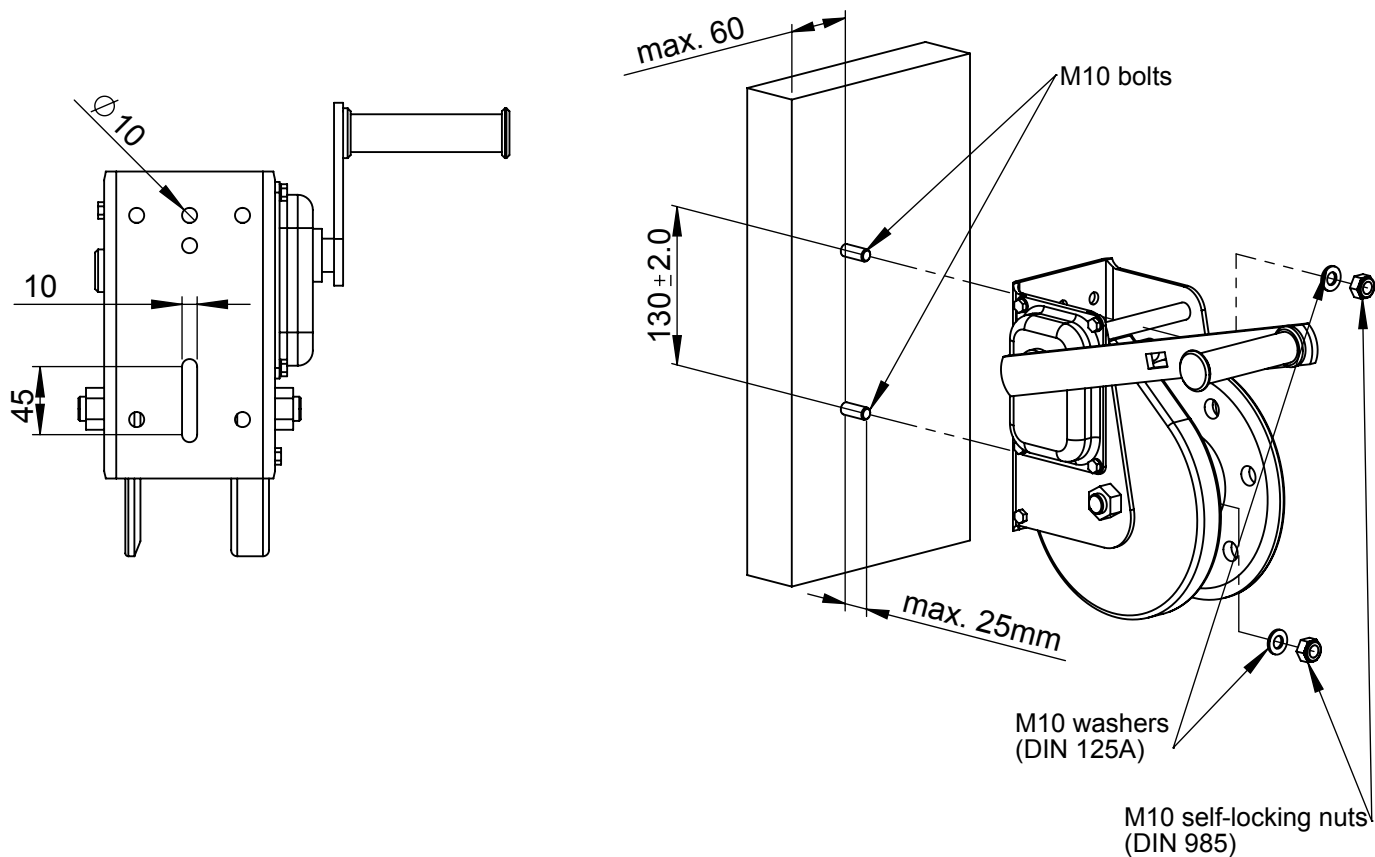

## INSTALLING ON THE STEEL PROFILE

1. To the narrow structural elements the winch should be installed using two holes ( $\varnothing 10$  mm and oblong  $\varnothing 10 \times 45$ ) situated on the back wall of the winch.
2. Device should be installed using two M10 steel bolts. Put the bolts through the back wall of the winch and through the structural anchor profile.
3. Put the washers M10 (DIN 125A) under the head of each bolt and under each nut. Tighten two M10 self-locking nuts (DIN 985).

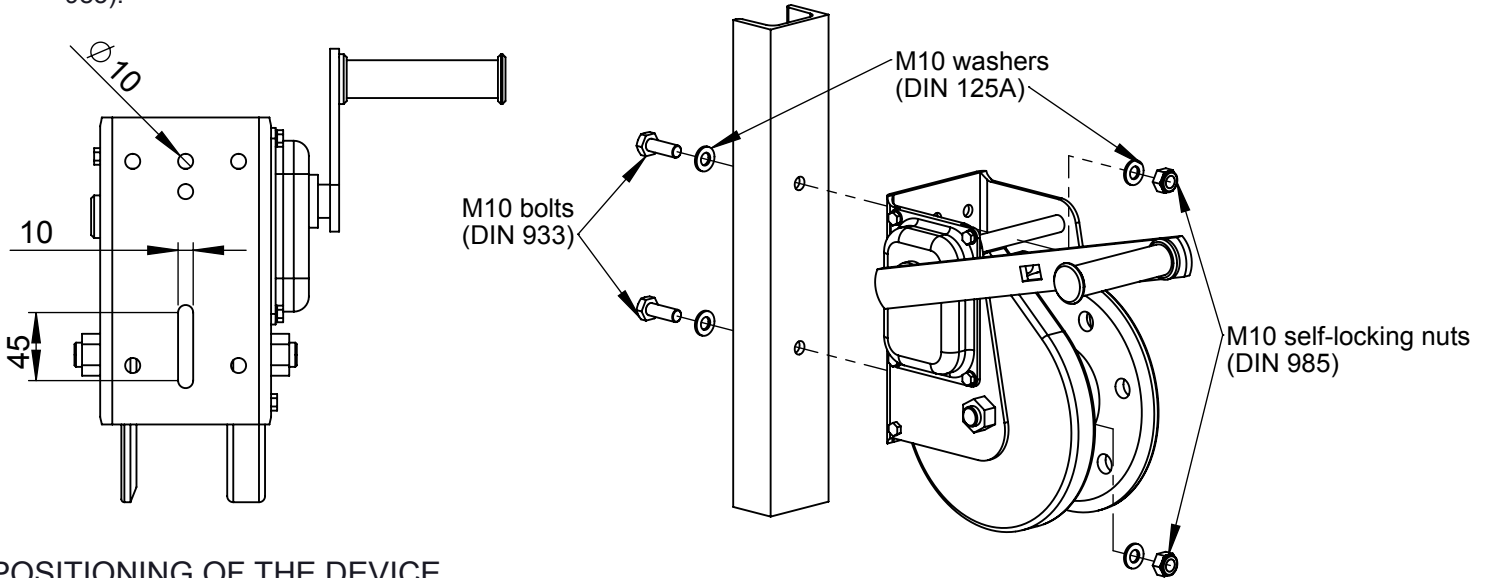

## POSITIONING OF THE DEVICE

1. Check the proper position of the device and correct guiding of the rope shown on the pictures below.
2. The construction element where the winch is installed must be vertical or horizontal.
3. Attach the energy absorber to the cable using the connector supplied with the absorber.
4. Connect absorber's connector to the attachment element of a harness. Use "A" frontal or dorsal attachment point in full body harness (EN 361) or rescue attachment point in rescue harness (EN 1497) or rescue loops (EN 1498).

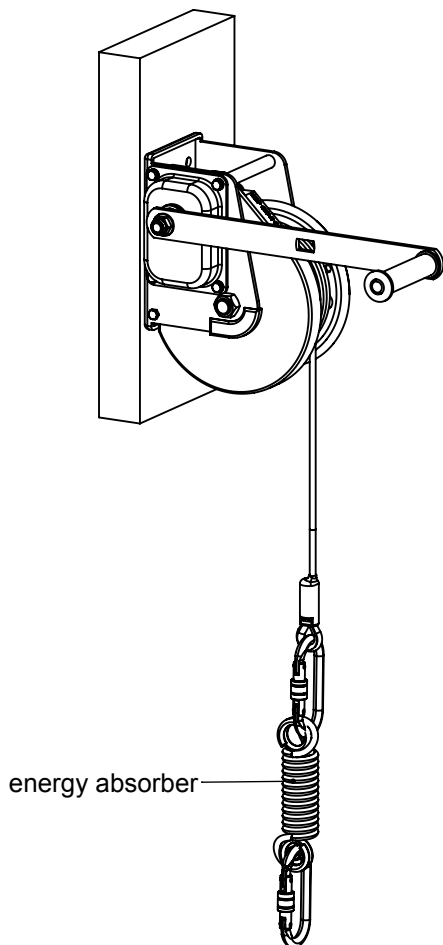

Device in a vertical position

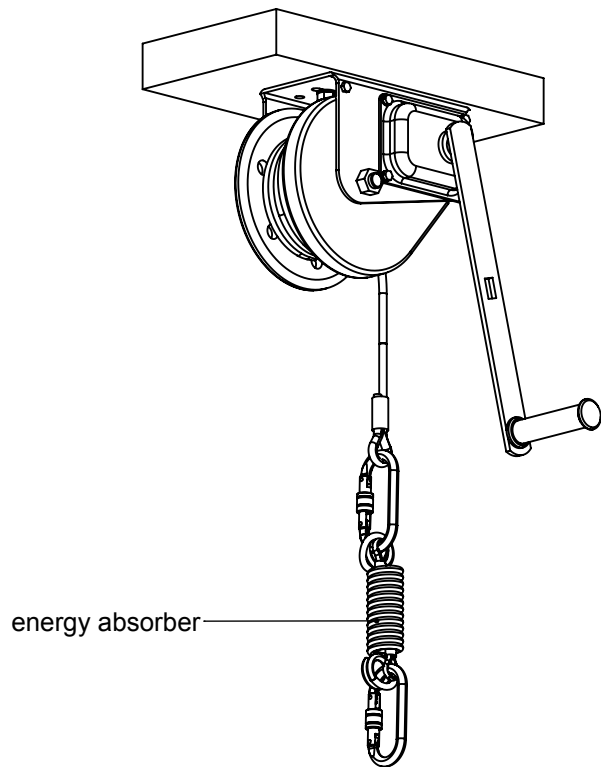

Device in a horizontal position

## CAUTION!

- It is forbidden to use the rescue lifting device as the protection against falls from height. When there is a danger of falling from a height additional secondary fall arrest system conforming EN 363 must be used.
- The lifting / lowering function is for rescue purposes only and not for lifting / lowering loads.
- Always operate the device with hand power and with crank included in the equipment only.
- Before each use of rescue device a thorough inspection must be carried out. Inspection must be carried out by a person using the device. In the case of damages and malfunctions, the device should be withdrawn from use.
- Never allow to full extension of the working rope from the reel. Keep at least three rope coils on the reel - it is marked by a special safety sign which is situated on the rope. Stop extend the rope from the reel when the red safety sign appears! Obligatory check a condition of the safety sign.
- There should be direct or indirect visual contact or some other means of communication with the rescuer at all times during the rescue process.
- Using the device, in connection with fall arrest system, must be compatible with manual instructions of the fall arrest systems and obligatory standards: EN 361, EN 1497, EN 1498, EN 341 - for body holding devices; EN 795 - for anchor devices; EN 353-1, EN 353-2, EN 354, EN 355, EN 360 - for fall arrest systems, EN 362 - for the connectors.

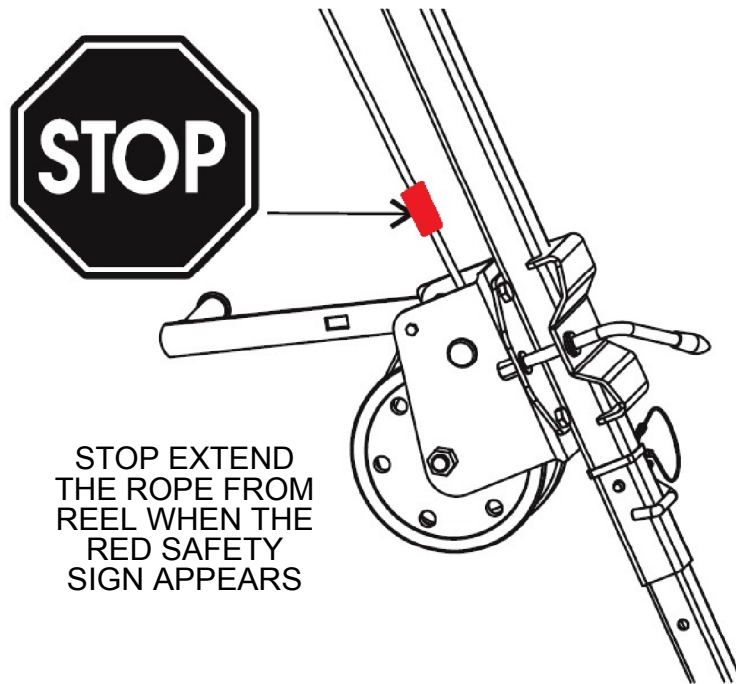

## THE ESSENTIAL PRINCIPLES OF USE PERSONAL PROTECTIVE EQUIPMENT

- Personal protective equipment (PPE) shall only be used by a person trained and competent in its safe use.
- PPE must not be used by a person with medical condition that could affect the safety of the equipment user in normal and emergency use.
- A rescue plan shall be in place to deal with any emergencies that could arise during the work.
- It is forbidden to make any alterations and additions to the equipment without manufacturer's prior written consent.
- Any repairs shall only be carried out by equipment manufacturer or his certified representative.
- PPE shall not be used outside its limitations, or of any purpose other than that for which it is intended.
- PPE should be a personal issue item.
- Before use ensure about the compatibility of items of equipment assembled into a fall arrest system. Periodically check connecting and adjusting of the equipment components to avoid accidental loosening or disconnecting of the components.
- It is forbidden to use combinations of items of equipment in which the safe function of any one item is affected by or interferes with the safe function of another.
- There are many hazards that may affect the performance of the equipment and corresponding safety precautions that have to be observed during equipment utilization, especially: (trailing or looping of lanyards or lifelines over sharp edges; any defects like cutting, abrasion, corrosion; climatic exposure; pendulum falls; extremes of temperature; chemical reagents; electrical conductivity).
- A full body harness conformed to EN 361 is the only acceptable body holding device that can be used in a fall arrest system.
- The anchor device or anchor point for the fall arrest system should always be positioned, and the work carried out in such a way, as to minimise both the potential for falls and potential fall distance. The anchor device/point should be placed above the user. The shape and construction of the anchor device/point shall not allowed to self-acting disconnection of the equipment. It is recommended to use certified and marked structural anchor point complied with EN 795.
- It is obligatory to verify the free space required beneath the user at the workplace before each occasion of use the fall arrest system, so that, in the case of a fall, there will be no collision with the ground or other obstacle in the fall path. The required value of the free space should be taken from instruction manual of used equipment.
- Using the energy absorber in conjunction with other elements of PPE must conform to the appropriate regulations and instruction manuals and current standards: EN 361 - for harnesses; EN 353-1, EN 353-2, EN 354, EN 360, EN 362 - for fall arrest systems; EN 795 - for structural anchor points/devices.
- In full body harnesses use only attaching points marked with big letter "A" to attach a fall arrest system. See the figures below:

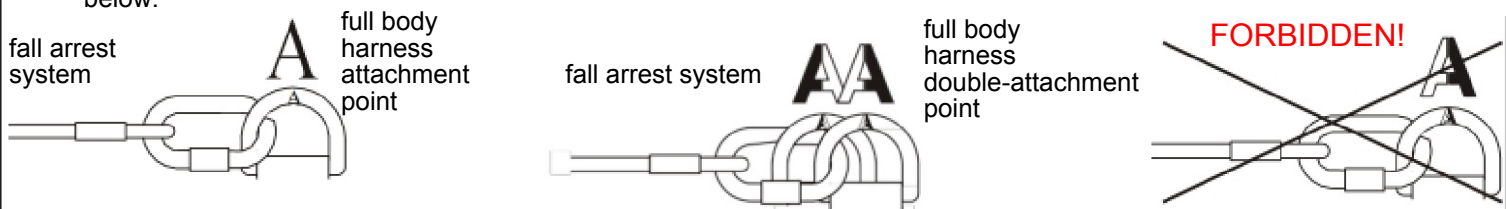

## **INSPECTION**

Before each use of Personal Protective Equipment (PPE) it is obligatory to carry out a pre-use check of the equipment, to ensure that it is in a serviceable condition and operates correctly before it is used.

During pre-use check it is necessary to inspect all elements of the equipment in respect of any damages, excessive wear, corrosion, abrasion, cutting or incorrect acting, especially in rescue lifting devices - cable (wires, clips, ferrules, loops, thimbles, connectors, adjusting elements) and automatic brake proper acting, casing, energy absorber (attaching loops, connectors), connectors (main body, rivets, gate, locking gear acting).

## **PERIODIC INSPECTION**

After each 12 months of utilization the rescue lifting device must be withdrawn from use to carry out manufacturer's detailed inspection. The inspection must be carried out by the rescue lifting device manufacturer or his certified representative only. During this inspection will be established admissible time of the device use till next manufacturer's inspection.

The result of inspection must be recorded in Identity Card.

Regular periodic inspections are the essential for equipment maintenance and the safety of the users which depends upon the continued efficiency and durability of the equipment.

During periodic inspections it is necessary to check the legibility of the equipment marking.

It is essential for the safety of the user that if the product is re-sold outside the original country of destination the reseller shall provide instruction for use, for maintenance, for periodic examination and for repair in language of the country in which the product is to be used.

## **WITHDRAWAL FROM USE**

Personal protective equipment must be withdrawn from use immediately when any doubt arise about its condition for safe use and not used again until confirmed in writing by equipment manufacturer or his certified representative after carried out the detailed inspection.

## **WITHDRAWAL FROM USE AFTER ARREST A FALL**

Personal protective equipment must be immediately withdrawn from use when it has been component of equipment used to arrest a fall. After that the detailed manufacturer's inspection must be carried out.

Detailed manufacturer's inspection can be carried out by:

- equipment manufacturer;
- or person recommended by manufacturer
- a company recommended by manufacturer.

During this inspection will be established if the device can be longer used and will be define the admissible time of device use till next manufacturer's inspection. If the device can not be longer used it will be subjected to destroyed.

## **TRANSPORTATION**

PPE must be transported in the package (e.g. bag made of moisture-proof textile or foil bag or cases made of steel or plastic) to protect it against damage or moisture.

## **MAINTENANCE AND STORAGE**

PPE can be cleaned and disinfected without causing adverse effect on the materials in the manufacture the equipment. For textile products use mild detergents for delicate fabrics, wash by hand or in a machine and rinse in water. Plastic parts can be cleaned only with water. When the equipment becomes wet, either from being in use or when due cleaning, it shall be allowed to dry naturally, and shall be kept away from direct heat. In metallic products some mechanic parts (spring, pin, hinge, etc.) can be regularly slightly lubricated to ensure better operation.

PPE should be stored loosely packed, in a well-ventilated place, protected from direct light, ultraviolet degradation, damp environment, sharp edges, extreme temperatures and corrosive or aggressive substances.

## CONTENT OF THE IDENTITY LABEL

- a) Device type.
- b) Model symbol.
- c) Reference number.
- d) Number/year/class of the European standard.
- e) Rescue equipment - information.
- f) Month and year of manufacture.
- g) Serial number of the tripod.
- h) Caution: read the manual.
- i) Marking of the manufacturer or distributor of the tripod.
- j) Maximum load limit.

The Notified Body involved with EC type examination and in the production control phase: APAVE SUDEUROPE SAS, CS 60193, 13322 Marseille, France.

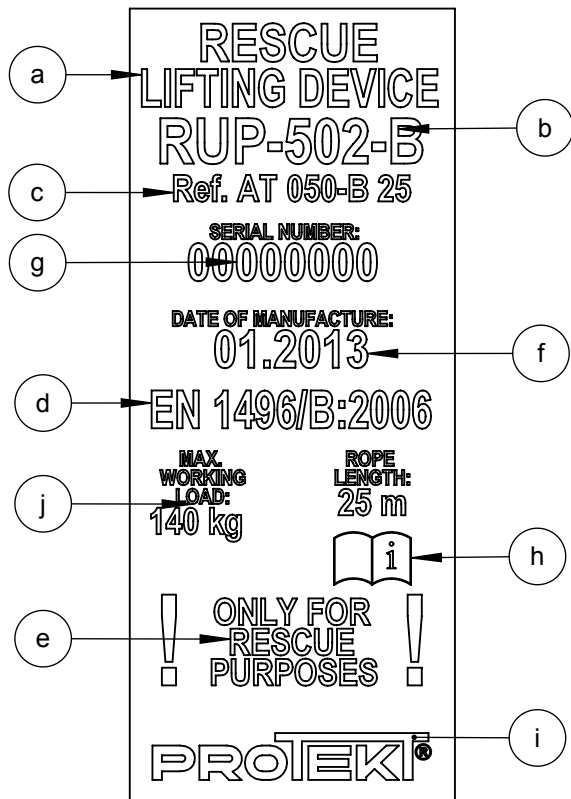

NOTES

.....

.....

.....

.....

## IDENTITY CARD

IT IS RESPONSIBILITY OF THE USER ORGANISATION TO PROVIDE THE IDENTITY CARD AND TO FILL IN THE DETAILS REQUIRED. THE IDENTITY CARD SHOULD BE FILLED IN ONLY BY COMPETENT PERSON RESPONSIBLE FOR PROTECTIVE EQUIPMENT. THE IDENTITY CARD SHOULD BE FILLED IN BEFORE THE FIRST USE OF THE EQUIPMENT. ANY INFORMATION ABOUT THE EQUIPMENT LIKE: PERIODIC INSPECTIONS, REPAIRS, REASONS OF EQUIPMENT'S WITHDRAWN FROM USE SHALL BE NOTED. THE IDENTITY CARD SHOULD BE STORED DURING A WHOLE PERIOD OF EQUIPMENT UTILIZATION. DO NOT USE THE EQUIPMENT WITHOUT THE IDENTITY CARD.

MODEL AND TYPE OF EQUIPMENT	
REF. NUMBER	
SERIAL NUMBER	
DATE OF MANUFACTURE	
DATE OF PURCHASE	
DATE OF FIRST USE	
USER NAME	

## PERIODIC EXAMINATION AND REPAIR HISTORY

	DATE	REASON FOR SERVICING / REPAIR	REPAIRS CARRIED OUT	NAME AND SIGNATURE OF COMPETENT PERSON	DATE OF NEXT EXAMINATION
1					
2					
3					
4					
5					
6					
7					
8					
9					

PRODUCER:

PROTEKT, 93-403 LODZ, ul. Starorudzka 9, POLAND, tel: +48 (42) 680 20 83, fax: +48 (42) 680 20 93, www.protekt.com.pl