

Models

BB15-COPM, BB30-COPM, BB50-COPM,
BB75-COPM, BB100-COPM, & BB150-COPM

Manual No. BREPNL17
(Rev 4 April 2006)



Operating Manual

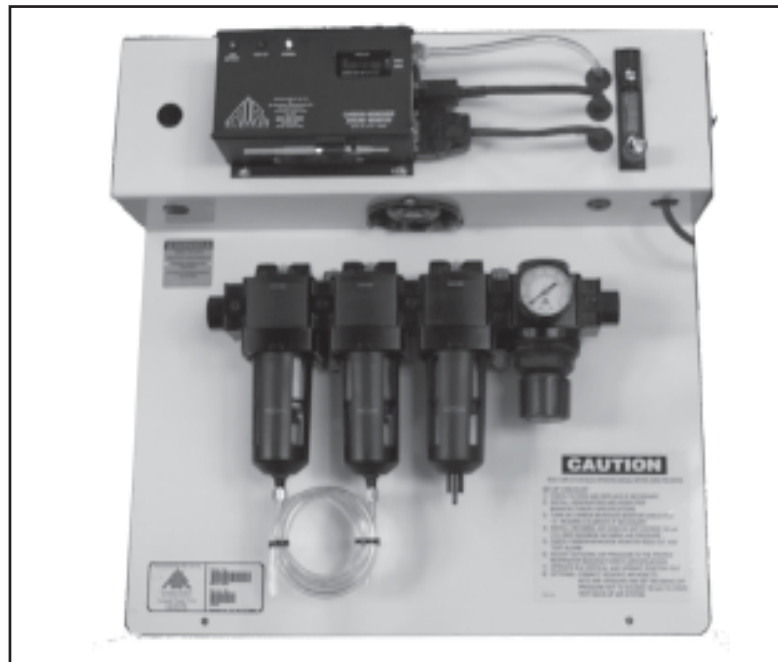

AIR SYSTEMS INTERNATIONAL, INC.

829 Juniper Crescent, Chesapeake, Va. , 23320

Telephone (757) 424-3967

Toll Free 1-800-866-8100

Fax No. (757) 424-5348

<http://www.airsystems.com>

e-mail: sales@airsystems.com

BREATHING AIR QUALITY POSITION STATEMENT

The responsibility for the quality of breathing air rests with the user. Compliance with federal, state, or local regulations is the responsibility of the user, and this recommendation does not supersede any existing rules, regulations, or laws which may apply. Breathing air filtration products meet or exceed CGA Grade-D specifications for air quality as adopted by Federal OSHA. Compressor air quality standards meet or exceed OSHA 1910.134 requirements. When the components are used in accordance with the manufacturer's instructions and recommendations, the "system" meets or exceeds federal regulations presently in force. It is incumbent upon the user to comply with any changes in the regulations or law which may occur in future situations.

The air supply compressor should be located in a safe, clean ambient air environment. This "safe" location should be tested periodically using proper instruments to ensure clean ambient air quality on a consistent basis. Total system Grade-D air quality should be tested at the time of initial setup. If the compressor is moved, retesting air quality is recommended. Should the location or environment significantly change, the air quality should be retested. The compressor filters and oil level should be checked daily and changed when contaminated or when the maximum number of "run" hours is achieved.

This series of air filtration units should be used according to the recommendations specified in the manual. The standard filtration package is not explosion-proof and should be located in a non-explosive environment. (An intrinsically safe model is available, please contact the factory for information.) The carbon monoxide monitor should be calibrated monthly or if the accuracy of the monitor is in question. System air quality should be tested for, but not limited to, the following Grade-D air components:

CO - Carbon Monoxide
 O₂ - Oxygen
 CO₂ - Carbon Dioxide
 H₂O - Water (Moisture Content)
 Hydrocarbons (Oil Mist)
 Total Particulates

The maximum allowable level of these air quality components varies depending on Grade-D or E requirements. Contact Sales for a copy of the latest standards.

Our Breathing Air compressors and filtration systems meet all of the following federal specifications when used and serviced in accordance with our instructions:

**Federal OSHA 29 CFR 1910.134
 "Compressor Operations for Breathing Air"
 Army Corps of Engineers EM385-1-1,
 paragraph 07b-11-4,
 "Compressed Breathing Air"**

FILTRATION EFFICIENCY

1st Stage	Particulate/Bulk Liquid Separation	Auto Drain and Filter change indicator. Removes 95% bulk particulate and liquids @ 5 microns
2nd Stage	Oil Coalescing and Ultra Fine Particulate	Auto Drain and Filter change indicator. Removes oil and particulate to 99.9998% @ 0.01 microns
3rd Stage	Activated Charcoal	Manual Drain and Filter change indicator. Removes organic vapors, odors, and tastes. Less than 0.003 pp/wt remaining oil content

Note: Filter Change Indicators are standard on all models except the BB15 series.

PANEL SPECIFICATIONS AND PARTS IDENTIFICATION

	BB15 SERIES	BB30 SERIES	BB50 SERIES	BB75 SERIES	BB100 SERIES	BB150 SERIES
Size	16" L x 15" H x 6"D	22"L x 23"H x 8"D	22"L x 23"L x 8"D	22"L x 23" H x 8" D	22"L x 23" H x 8" D	22"L x 23" H x 8" D
Weight	12.3 lbs/5.6 kg	19.7 lbs/8.0 kg	26.4 lbs/11.9 kg	34.2 lbs/15.5 kg	38.8 lbs/17.6 kg	38.8 lbs/17.6 kg
Inlet Thread Size	1/4" MPT	1/2" FPT	1/2" FPT	1/2" FPT	3/4" FPT	1" FPT
No. of Outlets	1	2 Standard 3 Optional	4	6 or Single 1/2" NPT Outlet	4-8 or Single 1/2" NPT Outlet	Single 1" NPT Outlet
Maximum Air Flow (cfm/bar)	15scfm @ 110psi 425 lpm @ 7.5 bar	30scfm @ 110psi 850 lpm @ 7.5 bar	50scfm @ 110psi 1415 lpm @ 7.5 bar	75scfm @ 110psi 2124 lpm @ 7.5 bar	100scfm @ 110psi 4248 lpm @ 7.5 bar	150scfm @ 110psi 4955 lpm @ 7.5 bar
AC Remote Alarm Signal	No	Yes	Yes	Yes	Yes	Yes
Maximum Inlet Pressure	150psi (10.3 bar)					
Relief Valve	125psi (8.6 bar)					
Monitoring	Inline Continuous Monitoring of Carbon Monoxide (CO)					
Power	9-16 VDC or 110-120 VAC 50/60 Hz					

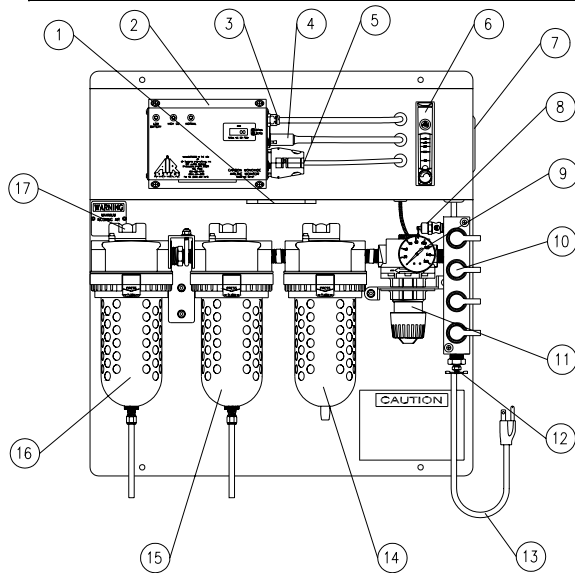

ITEM #	DESCRIPTION 30 - 150 Series
1	HIGH CO AUDIBLE ALARM
2	CO MONITOR, P/N CO-91ACRL
3	AIR SAMPLE INLET
4	POWER PLUG, 115 VAC
5	REMOTE SIGNAL CONNECTOR
6	FLOWMETER
7	115 VAC REMOTE ALARM GANG BOX
8	RELIEF VALVE
9	PRESSURE GAUGE
10*	RESPIRATOR CONNECTIONS
11	PRESSURE REGULATOR
12	DRAIN COCK
13	POWER CORD
14	CHARCOAL FILTER
15	COALESCING FILTER
16	PARTICULATE FILTER
17	FILTER CHANGE INDICATOR

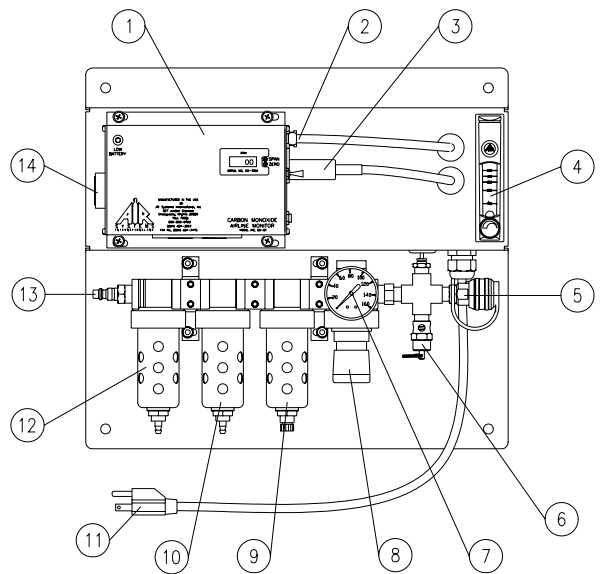

ITEM #	DESCRIPTION BB15-COPM
1	CO MONITOR, P/N CO-91A
2	AIR SAMPLE INLET
3	POWER PLUG
4	FLOWMETER
5	RESPIRATOR CONNECTION
6	RELIEF VALVE
7	PRESSURE GAUGE
8	PRESSURE REGULATOR
9	CHARCOAL FILTER
10	COALESCING FILTER
11	POWER CORD
12	PARTICULATE FILTER
13	INLET FITTING
14	HIGH CO AUDIBLE ALARM

*Note: Some models may not have respirator connections. They can be ordered with NPT outlets for connection to drop stations or points of attachment.

MONITOR OVERVIEW

The monitor will analyze the air sample and display the CO concentration in parts-per-million (ppm). The system's green "NORMAL" operation light will illuminate and the red "HIGH CO" light will flicker faintly approximately every second when the CO level is below 10ppm (5ppm Canadian). If the CO concentration level exceeds the alarm set point, the green "NORMAL" light will turn off, the red "HIGH CO" light will illuminate, the audible alarm will sound and the remote alarm connections (if used) will energize. Once the CO concentration levels drop below the alarm set point, all alarm indicators will deactivate and the unit will return to "NORMAL" operation.

MONITOR SPECIFICATIONS

Size	2.75"H x 6.57"L x 5.1"W
Weight	2.8 LBS. (1.27KG)
Case	Extruded aluminum - Anodized black
Voltage	115 VAC and/or 9 - 16 VDC
Shielding	Internal RFI/EMI filters
Fuse	115 VAC 1 amp fast acting
Operating Temperature	4 to 113 degrees F (-15.5 to 45 degrees C)
Humidity Range	10% to 90% RH
Flow Requirement	50 - 100 cc
Display	3 digit LCD (CO concentration)

Test Circuit	Manually activated
Sensor Type	Sealed electrochemical sensor for Carbon Monoxide
Accuracy	+/- 1% full scale
Response	90% in 10-15 seconds
Detectable Range	0 - 200ppm CO
Calibration	Manual CO zero and span adjustments
Alarm Setting	10ppm CO (5ppm Canadian)
Warning Signals	Normal operation - Green light High CO - Red Light High CO - Audible Alarm Low Battery - Amber Light
Warranty	2 years from original date of purchase

WIRING SCHEMATIC

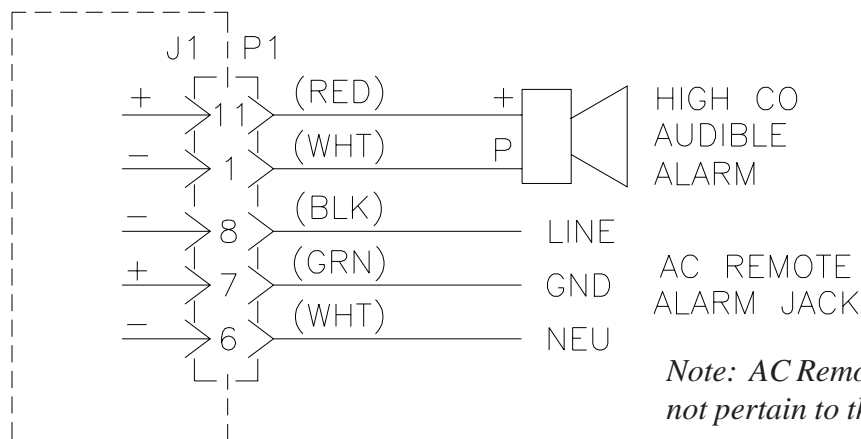

MONITOR IDENTIFICATION

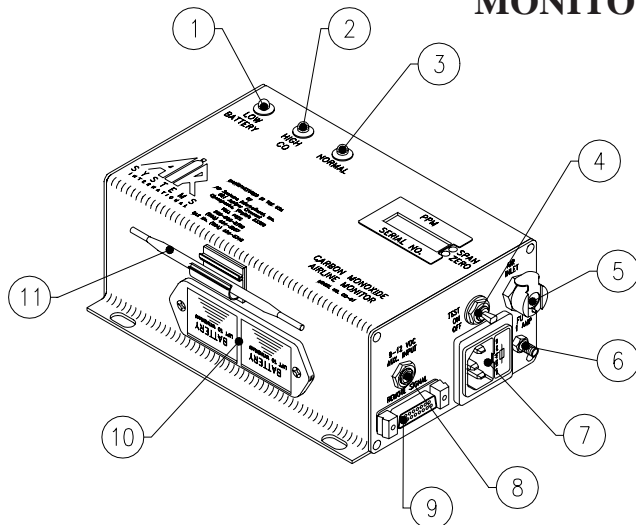

ITEM #	DESCRIPTION
1	LOW BATTERY INDICATOR
2	HIGH CO INDICATOR
3	NORMAL
4	ON/OFF/TEST SWITCH
5	AIR SAMPLE INLET
6	AIR DISCHARGE PORT (DO NOT BLOCK)
7	120 VAC RECESS PLUG WITH FUSE HOLDER (1 AMP FAST ACTING)
8	AUXILIARY DC POWER INPUT JACK
9	REMOTE SIGNAL CONNECTOR
10	BATTERY HOLDER
11	CALIBRATION TOOL

PANEL SETUP AND OPERATION

STEP 1)

Secure a primary air source of sufficient air flow and discharge pressure. The number and type of respirators being used determines the flow rate and pressure required.

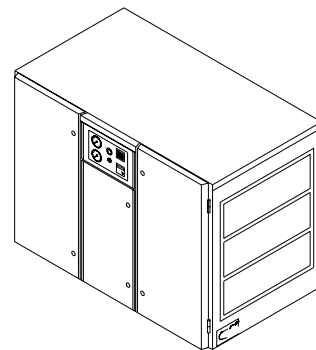

STEP 2)

Check air line monitor for fresh 9-volt batteries and turn the unit on. Connect the remote signal cable, 115 VAC plug, and air sample hose to the monitor.

Note: *Remote signal cable does not apply to BB15 series panels.* Place the "ON/OFF/TEST" switch to the "ON" position. Allow 30 seconds for the readout to stabilize. If a reading other than "ZERO" is displayed, calibration of the monitor may be necessary. See calibration procedure.

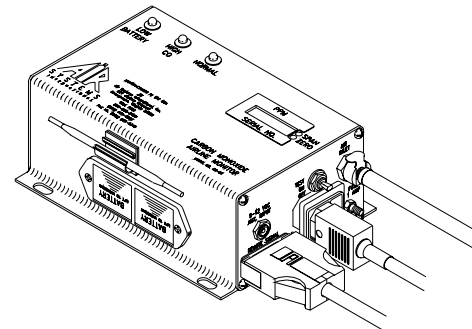

STEP 3)

Connect the power cord to a 115 VAC receptacle. **Note:** *The CO monitor can run off the twin 9-volt batteries if no AC power is available.* If the optional AC remote signal is used, 115 VAC power must be connected.

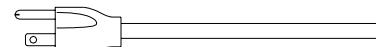

STEP 4)

Connect the remote alarm assembly (optional) to the remote alarm gang box (115 VAC only). **Note:** *Does not apply to BB15 series panels.*

Black - Line
White - Neutral
Green - Ground

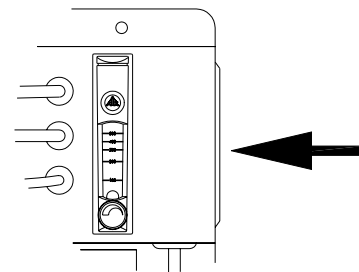

STEP 5)

Close the flowmeter by turning the control knob fully clockwise.

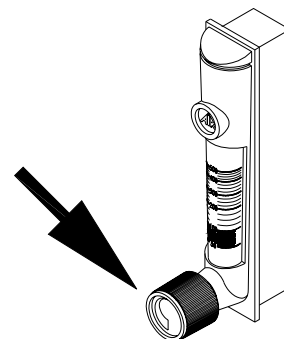

STEP 6)

Attach a 1/2" (1/4" for BB-15 series) industrial interchange coupling and hose to the inlet fitting and the compressed air source. Panels may be ordered hard piped for permanent installation. Refer to page 4 Specifications for proper pipe thread size.

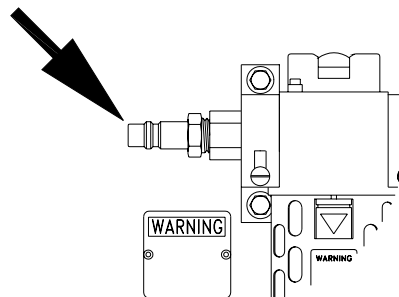
**STEP 7)**

Hold the "ON/OFF/TEST" switch in the "TEST" position. All local and remote audible/visual indicators will activate. If indicators do not activate, check all electrical connections, then call factory repair department.

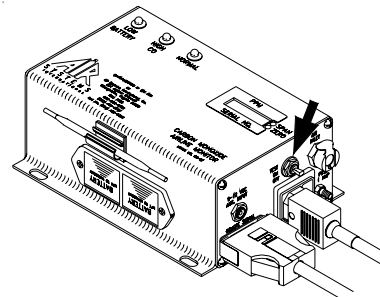
**STEP 8)**

Attach the desired respirators and lengths of hose to the quick connect outlet couplings. *Note: Some models may not have respirator connections. They can be ordered with NPT outlets for connection to drop stations or point of attachments.*

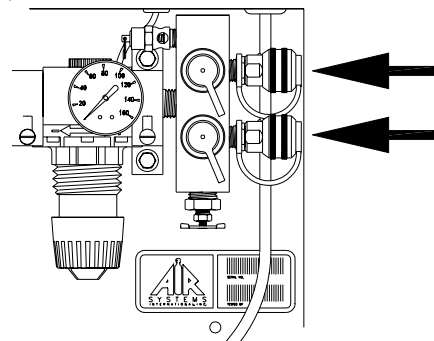
**STEP 9)**

Adjust the outlet pressure to the setting recommended by the respirator manufacturer. Turn the knob clockwise to increase pressure, counterclockwise to decrease pressure.

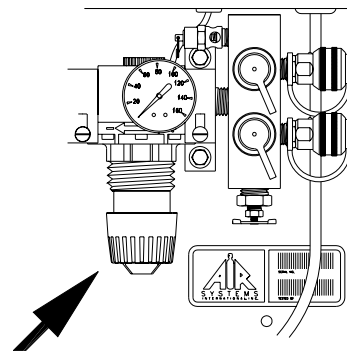
**STEP 10)**

Adjust CO monitor air sample flow rate by turning the flowmeter control knob counterclockwise until the float hovers in the green bar area (approximately 50-100 cc/min). The panel is now ready for operation.

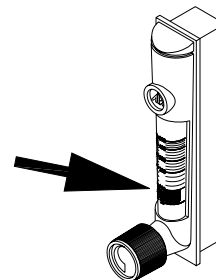

SHUTDOWN

- 1) Make sure all personnel have egressed from the work area.
- 2) Shut off air source to the panel.
- 3) Remove air pressure from the panel by pulling out the relief valve ring.
- 4) Turn monitor "OFF" at the "ON/OFF/TEST" switch. **Do not** remove 9-volt batteries. These are used to maintain a bias voltage to the sensors; this keeps the sensor ready for immediate future use.
- 5) Disconnect airline hoses.
- 6) Install dust caps, if applicable.

SYSTEM MAINTENANCE



CAUTION: Always depressurize the system before performing service.

Filter Housing/Bowls: Periodic cleaning of the polycarbonate bowls may become necessary. Remove the auto drains. Clean the bowls with a mild soapy solution. Reinstall into the filter housing.

Auto Drains: The automatic drains are designed to remove bulk liquid contaminants. The drains (1st & 2nd stages only) will automatically drain the liquids after the level has reached 1/3 of the bowl capacity. For periodic cleaning, use a mild soapy solution.

Filter Change: The filtration system consists of a filter change indicator which will gradually change from green to orange when filter life is spent. (Not available on BB15 series)

Note: *Air must be flowing through the filtration unit before the filter change indicators will function.*

Calibration: Monitor calibration can be done by any competent person and should be done monthly or whenever the reading may be questionable. A calibration date sticker should be affixed for future reference. To obtain an accurate calibration, we recommend the use of Air Systems' calibration kits and follow the calibration procedure in this manual.

Part Number:

- BBK-20** Calibration kit for CO monitor, 20ppm CO, zero air, regulator and case - 17 liter size.
- BBK-10** Canadian Calibration kit for CO monitor, 10ppm CO, zero air, regulator and case - 17 liter size.
- BBK-20103** Calibration kit for CO monitor, 20ppm CO, zero air, regulator and case - 103 liter size.

To assure sensor accuracy, calibration of the monitor is required. If you cannot obtain an accurate calibration, sensor replacement may be necessary. **Consult Repair Service Department before ordering.**

Part Number:

- CO-91NS** New Replacement Sensor

Battery Replacement: Replace 9-volt batteries when the amber "LOW BATTERY" light illuminates. If the monitor is not used for 90 days, check the 9-volt battery condition and replace if necessary.

MONITOR BATTERY REPLACEMENT

These batteries continuously provide a required bias voltage to the CO sensor and power the monitor in the event of AC power loss. If AC and DC power are removed for a period of 2 hours or more, a 1 hour restabilization period is required on the sensor as erratic readings may occur.

Batteries approved for use are:

1. Panasonic Industrial Alkaline Battery - 9 VDC Model No. 6AM - 6PI 9V
2. Duracell Alkaline Battery - 9 VDC Model No. MN1604B2
3. Eveready Battery (Energizer) Alkaline 9VDC - Model No. 6LR61-6AM6-9V

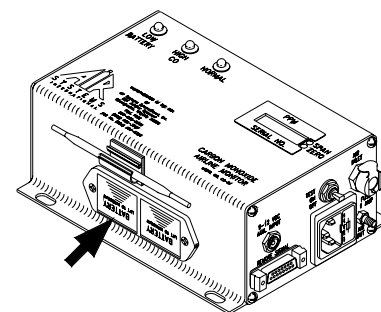

SENSOR REPLACEMENT

Replacement sensors are shipped with a metal spring installed between the electrodes. **Do not** remove the clip until the sensor is to be installed into the monitor.

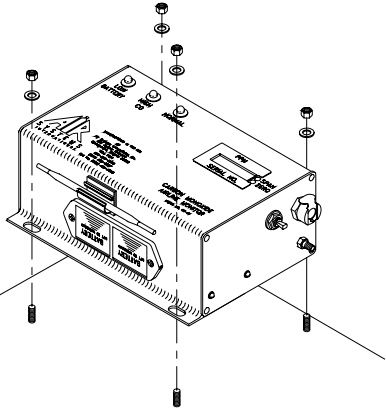

STEP 1)

Disconnect all external connections. Remove CO monitor from the unit.

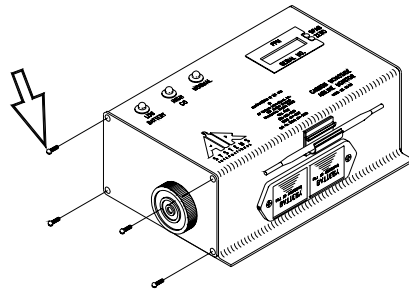

STEP 2)

Remove the four screws from the monitor's left end plate.
Note: Alarm location may vary.

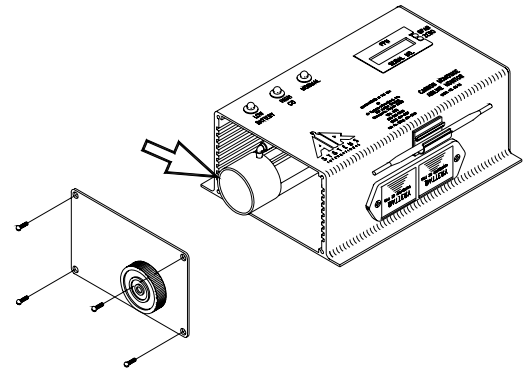

STEP 3)

Remove end plate to gain access to the sensor cup from outside the housing.

Note: Currently, there are two types of sensors being shipped. Please check your sensor lead connections and follow sensor connection instructions below.

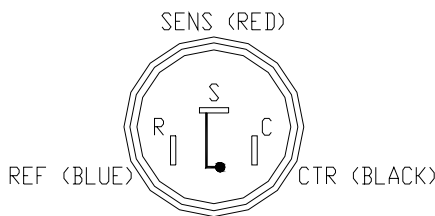
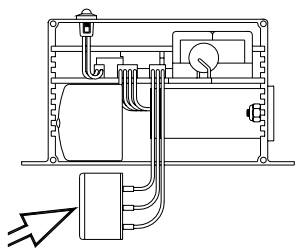

SENSOR CONNECTIONS ARE AS FOLLOWS:
RED LEAD - SENSING
BLUE LEAD - REFERENCE
BLACK LEAD - CONTROL

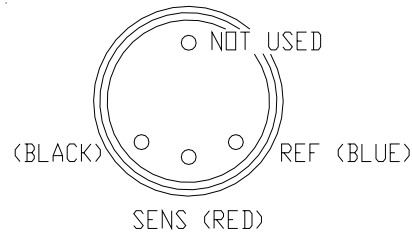

SENSOR CONNECTIONS ARE AS FOLLOWS:
RED LEAD - SENSING
BLUE LEAD - REFERENCE
BLACK LEAD - CONTROL

STEP 4)

Remove sensor from sensor cup and remove leads. Take the new sensor and remove the metal spring. Reattach leads to the proper colored terminals on the new sensor. Install new sensor into sensor cup.

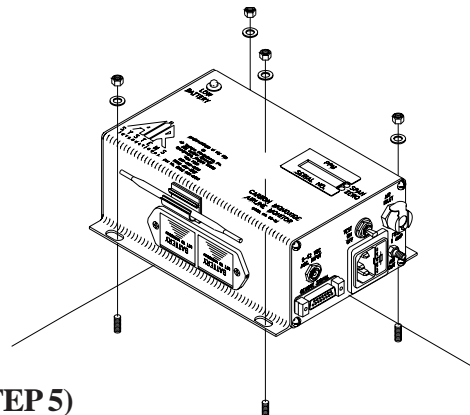

STEP 5)

Reassemble monitor and install back into system. Connect all external connections. Allow monitor to stabilize 30 minutes to 1 hour and recalibrate.

CALIBRATION PROCEDURE

Do not use inert gases to zero the monitor. This will cause premature failure of the sensor.

CO Zero Adjustment

To zero the instrument, follow the steps below. Zero calibration gas should be used to properly “zero” the instrument and assure that a valid calibration is achieved. If zero adjustment cannot be made as indicated, sensor replacement may be necessary. ***After each monitor adjustment outlined in the following steps, allow time for the changes to stabilize.***

1. Place the “on/off/test” switch to the “on” position.

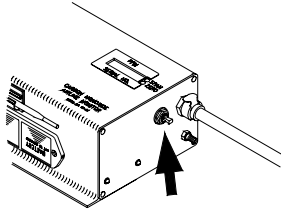

2. Allow 30 seconds for the readout to stabilize. The green indicator light will illuminate.

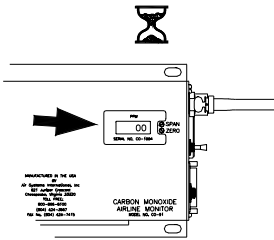

3. Hold the “on/off/test” switch in the “test” position. The following will occur:

- Audible alarm will sound
- Green indicator LED will flash
- Amber low battery indicator LED will illuminate
- Red lamp on

This test ensures the circuitry is operable and the continuity to the sensor is proper. Release the switch.

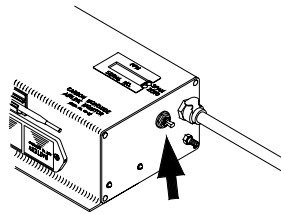

4. Remove air sample inlet tube.

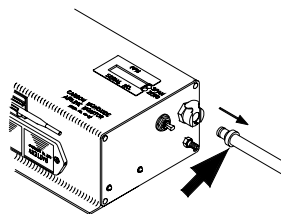

5. Install regulator on the zero air cylinder reference gas.

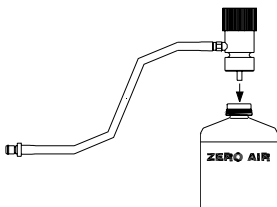

6. Attach the clear tubing with male plug to the monitor air sample inlet.

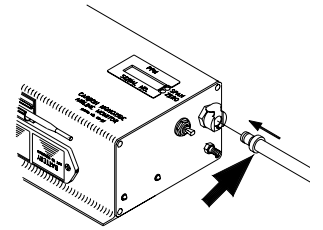

7. Turn knob slightly counterclockwise to allow the flow of gas through the hose. Verify flow of gas through the hose via touch or sound.

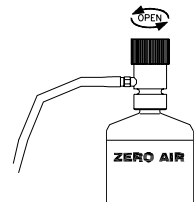

8. Allow digital readout to stabilize approximately 15 - 30 seconds.

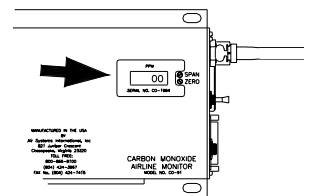

9. Adjust "zero" pot adjustment screw (clockwise to increase, counterclockwise to decrease) until a "00" reading is obtained.

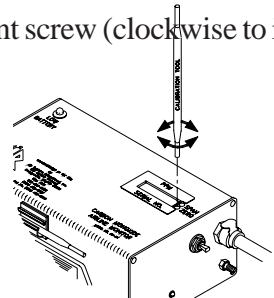

10. Turn off the regulator and disconnect the tubing from the zero air regulator.

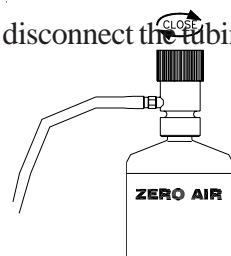

CO SPAN ADJUSTMENT

Use only 10 - 20 ppm CO gas for calibration. Using a higher concentration may decrease accuracy at lower scale readings. Note: 10ppm gas must be used to satisfy Canadian calibration requirements.

1. Install regulator to the CO calibration gas cylinder.

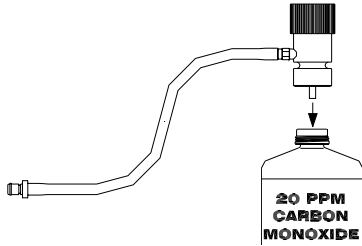

2. Connect the plug to the monitor.

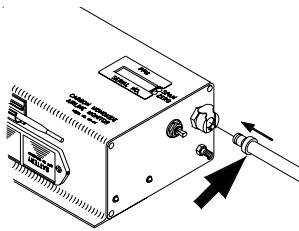

3. Turn knob slightly counterclockwise to allow the flow of gas through the hose. Verify flow of gas through the hose via touch or sound.

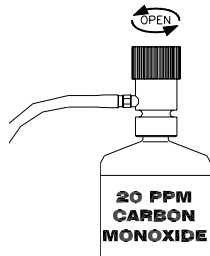

4. Allow digital display to stabilize approximately 15 - 30 seconds.

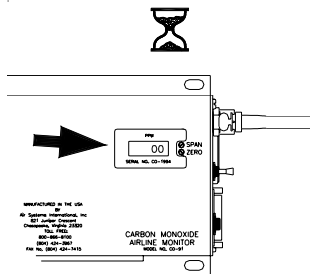

5. Adjust the "span" pot adjustment screw (clockwise to increase, counterclockwise to decrease) until the digital display reads the same concentration (ppm) as printed on the calibration gas cylinder.

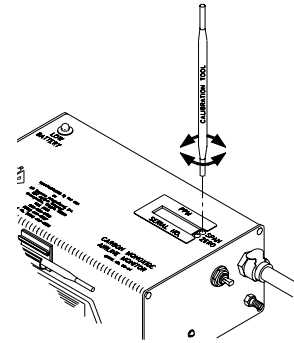

6. Turn regulator off and repeat "zero" adjustment procedure above. Display should return to a "00" reading.

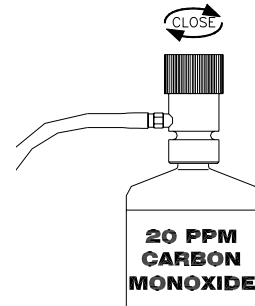

THE MONITOR IS NOW CALIBRATED AND SHOULD BE RECALIBRATED MONTHLY OR IF ACCURACY IS QUESTIONABLE. CHECK LOCAL REQUIREMENTS AND RECALIBRATE AS REQUIRED.

MODEL BB15-COPM REPLACEMENT FILTER BREAKDOWN

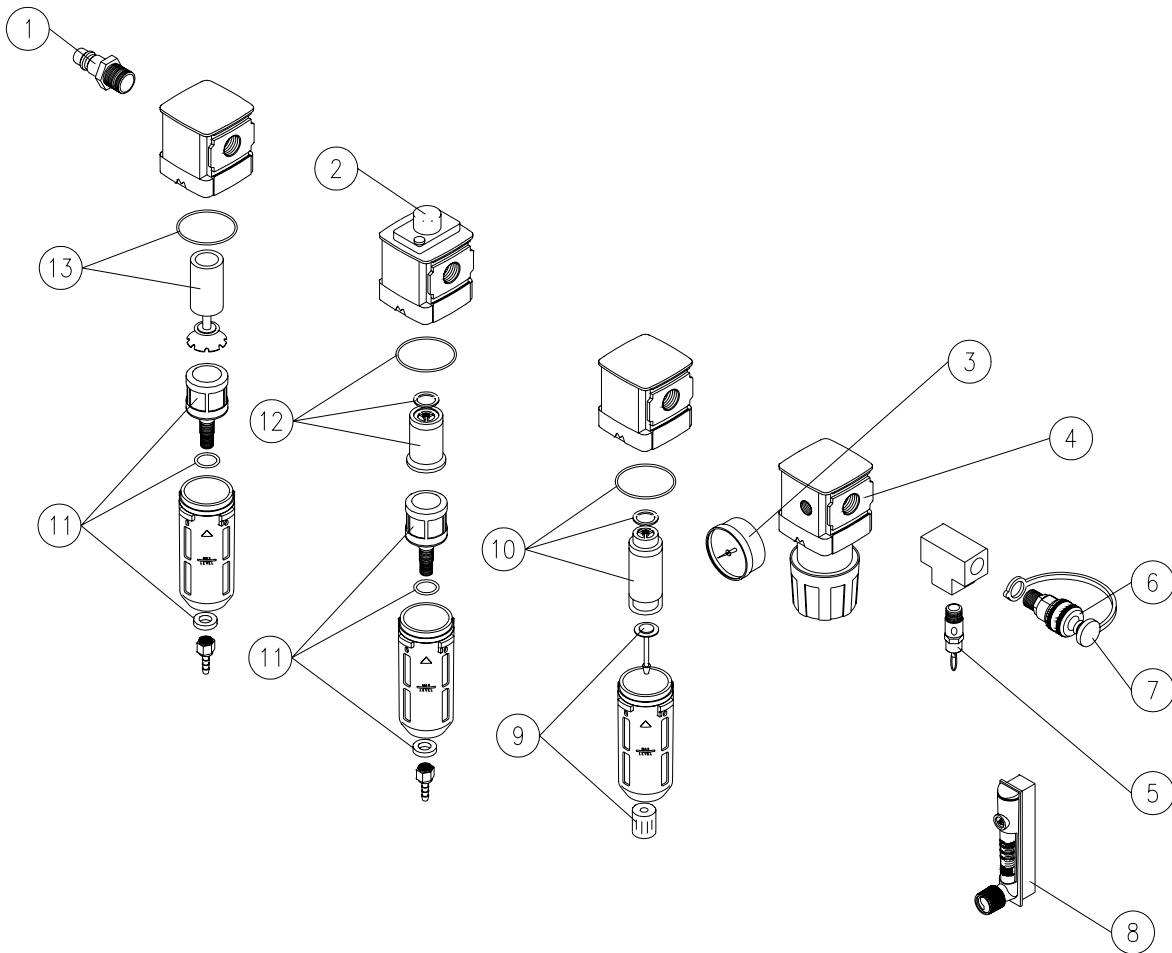

ITEM #	DESCRIPTION	15 CFM
1	INLET FITTING	QDH3PL6M
2	FILTER CHANGE INDICATOR	15DPW
3	PRESSURE GAUGE	GA20160B
4	PRESSURE REGULATOR	15REGW
5	RELIEF VALVE, 125 PSI	VR4125BR
6	HANSEN COUPLING	QDH3SL6M
6A	SCHRADER COUPLING	QDSSL6M
7	HANSEN DUST CAP	QDH3DCAP
7A	SCHRADER DUST CAP	QDSDCAP
8	FLOWMETER	WL033NS
9	MANUAL DRAIN	15MDW
10	"D" FILTER ELEMENT	BB15-DW
11	AUTO DRAIN ASSEMBLY	BB15-AD
12	"C" FILTER ELEMENT	BB15-CW
13	"A" FILTER ELEMENT	BB15-AW
14	FILTER BOWL O-RING	*

NOTE: FOR UNITS PURCHASED PRIOR TO 12/04, PLEASE CONTACT CUSTOMER SERVICE FOR CORRECT ORDERING INFORMATION ON FILTER REPLACEMENT ELEMENTS.

MODEL BB30-COPM REPLACEMENT FILTER BREAKDOWN

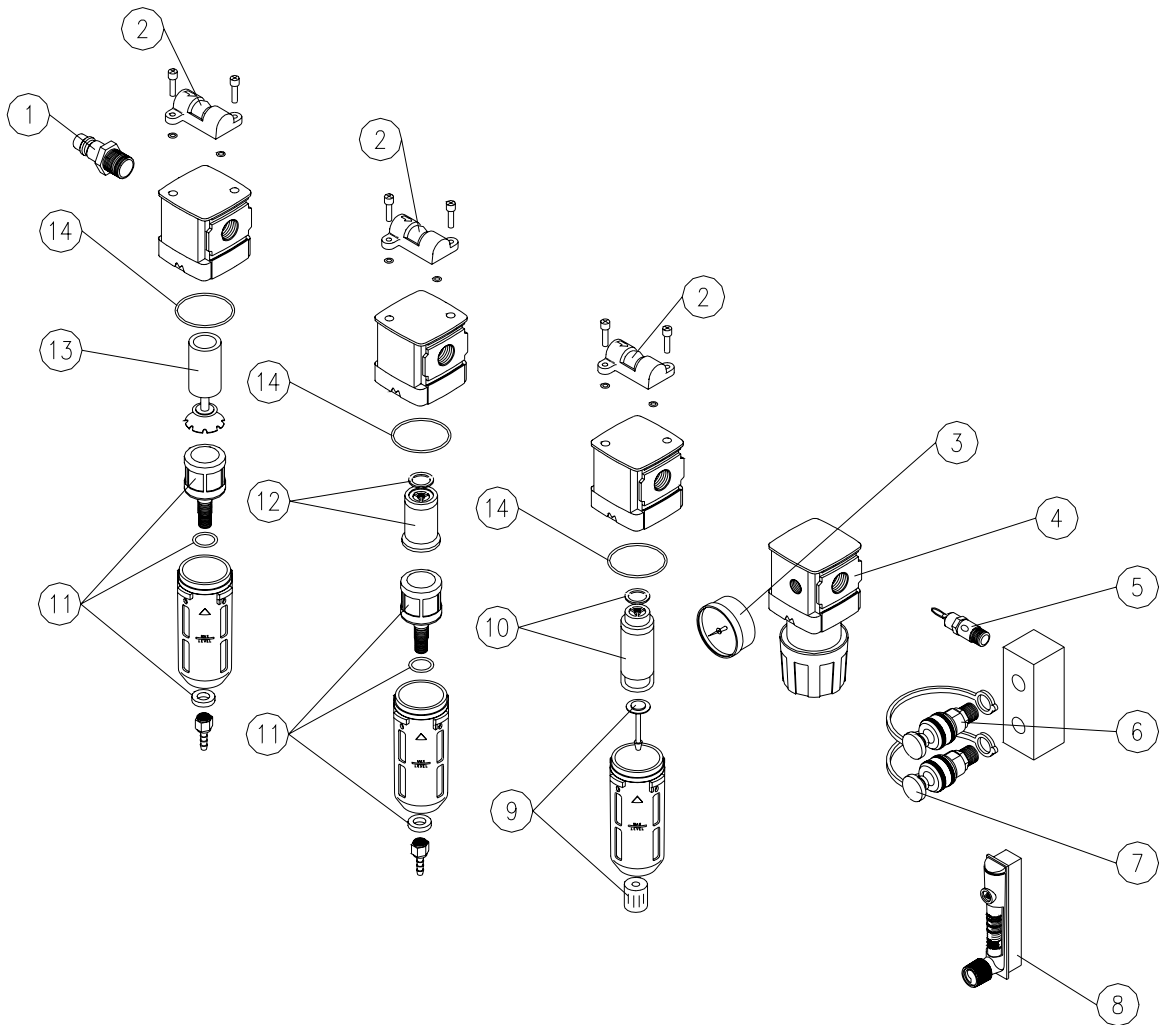

ITEM #	DESCRIPTION	30 CFM
1	INLET FITTING	QDH5PL8M
2	FILTER CHANGE INDICATOR	WL261
3	PRESSURE GAUGE	GA20160B
4	PRESSURE REGULATOR	WL257
5	RELIEF VALVE, 125 PSI	VR4125BR
6	HANSEN COUPLING	QDH3SL6M
6A	SCHRADER COUPLING	QDSSL6M
7	HANSEN DUST CAP	QDH3DCAP
7A	SCHRADER DUST CAP	QDSDCAP
8	FLOWMETER	WL033NS
9	MANUAL DRAIN	WL262
10	"D" FILTER ELEMENT	BB30-D
11	AUTO DRAIN ASSEMBLY	WL024
12	"C" FILTER ELEMENT	BB30-C
13	"A" FILTER ELEMENT	BB30-A
14	FILTER BOWL O-RING	WL266

MODEL BB50-COPM REPLACEMENT FILTER BREAKDOWN

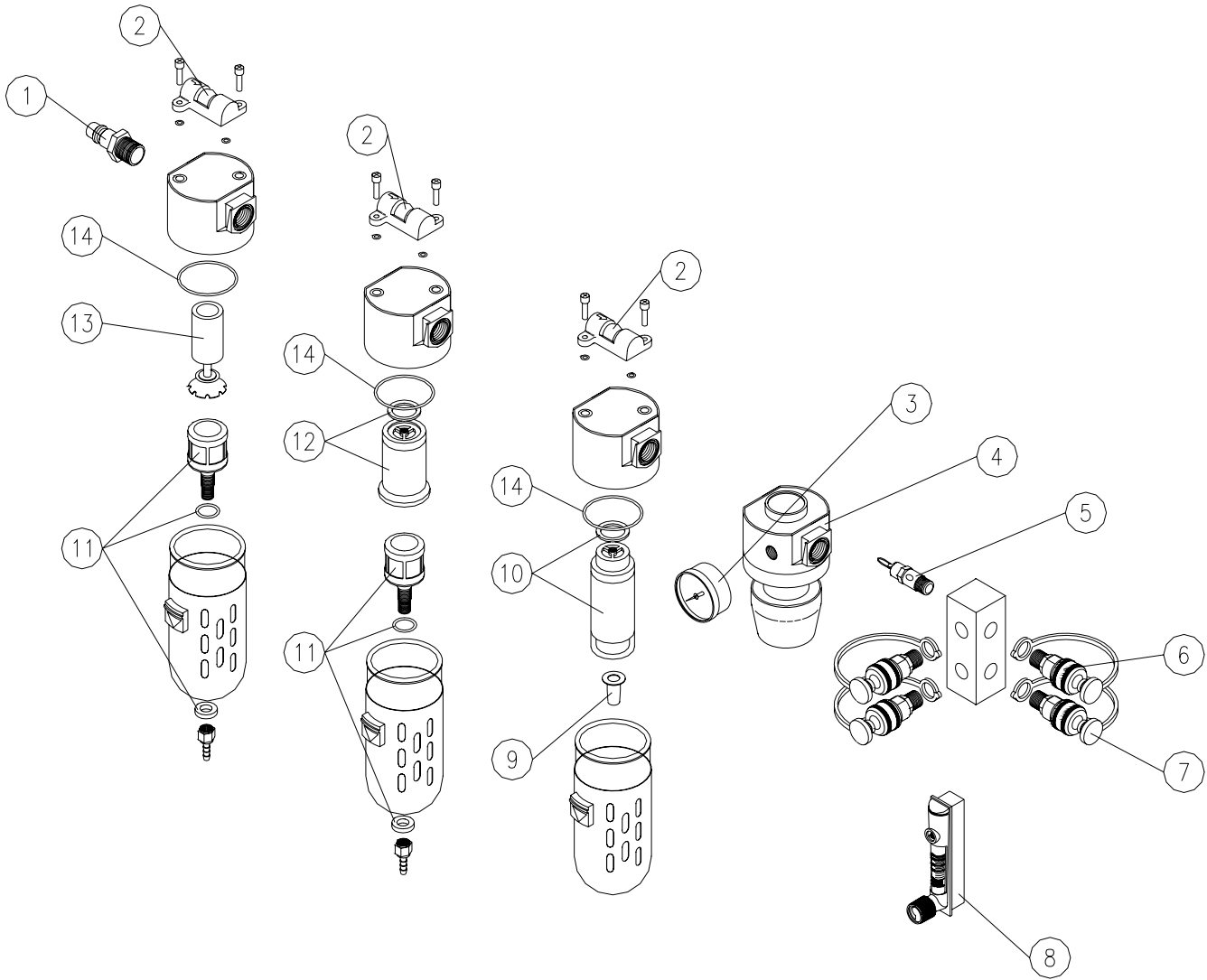

ITEM #	DESCRIPTION	50 CFM
1	INLET FITTING	QDH5PL8M
2	FILTER CHANGE INDICATOR	WL056
3	PRESSURE GAUGE	GA20160B
4	PRESSURE REGULATOR	WL015
5	RELIEF VALVE, 125 PSI	VR4125BR
6	HANSEN COUPLING	QDH3SL6M
6A	SCHRADER COUPLING	QDSSL6M
7	HANSEN DUST CAP	QDH3DCAP
7A	SCHRADER DUST CAP	QDSDCAP
8	FLOWMETER	WL033NS
9	MANUAL DRAIN	WL153
10	"D" FILTER ELEMENT	BB50-D
11	AUTO DRAIN ASSEMBLY	WL024
12	"C" FILTER ELEMENT	BB50-C
13	"A" FILTER ELEMENT	BB50-A
14	FILTER BOWL O-RING	WL091

PLASTIC BOWL PART #WL049 (NOT SHOWN)

MODEL BB75-COPM REPLACEMENT FILTER BREAKDOWN

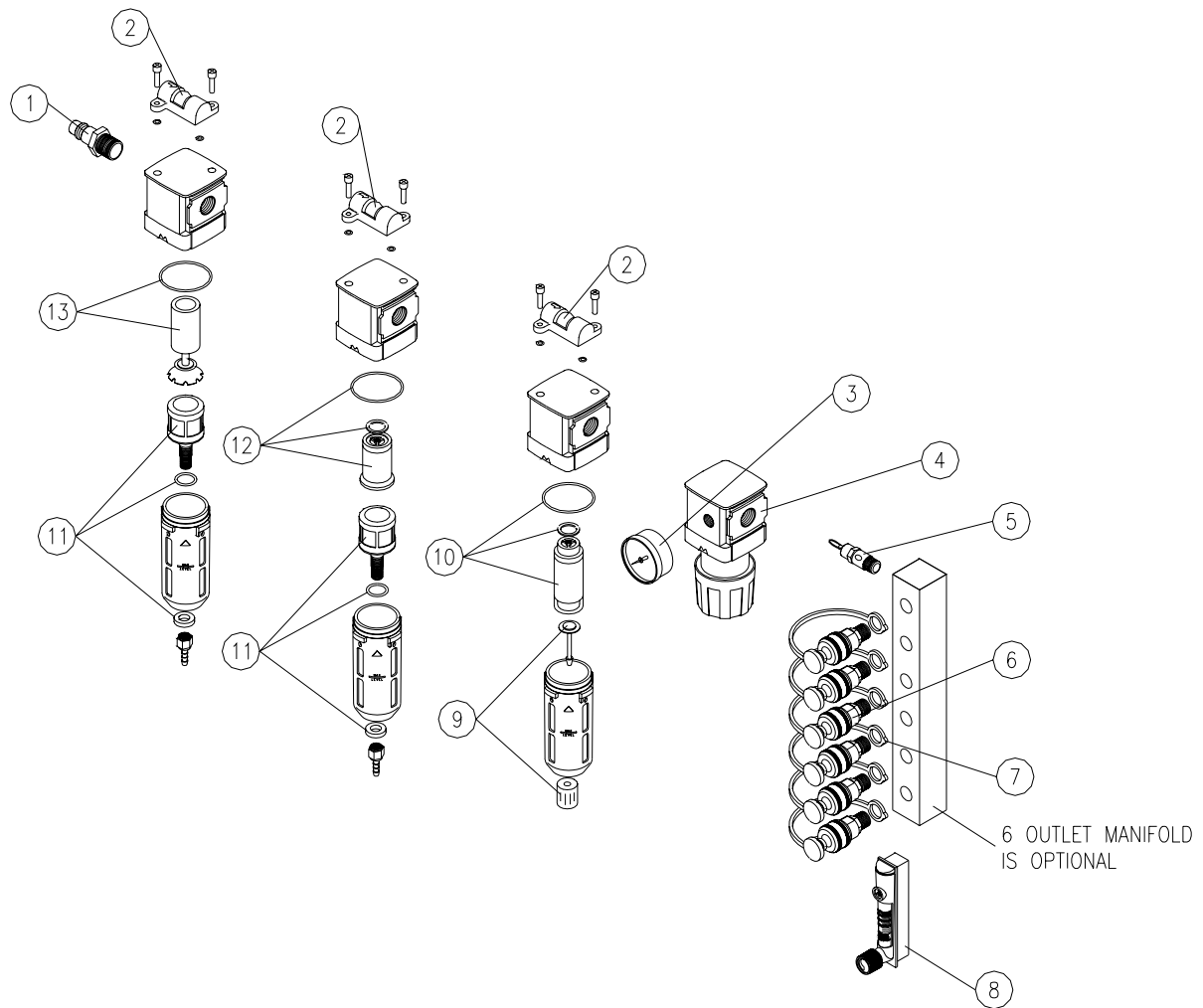

ITEM #	DESCRIPTION	75 CFM
1	INLET FITTING	QDH5PL8M
2	FILTER CHANGE INDICATOR	WL261
3	PRESSURE GAUGE	GA20160B
4	PRESSURE REGULATOR	WL181
5	RELIEF VALVE, 125 PSI	VR4125BR
6	HANSEN COUPLING	QDH3SL6M
6A	SCHRADER COUPLING	QDSSL6M
7	HANSEN DUST CAP	QDH3DCAP
7A	SCHRADER DUST CAP	QDSDCAP
8	FLOWMETER	WL033NS
9	MANUAL DRAIN	WL262
10	"D" FILTER ELEMENT	BB75-D
11	AUTO DRAIN ASSEMBLY	WL024
12	"C" FILTER ELEMENT	BB75-C
13	"A" FILTER ELEMENT	BB75-A
14	FILTER BOWL O-RING	*
* INCLUDED WITH FILTER ELEMENT		

MODEL BB100-COPM REPLACEMENT FILTER BREAKDOWN

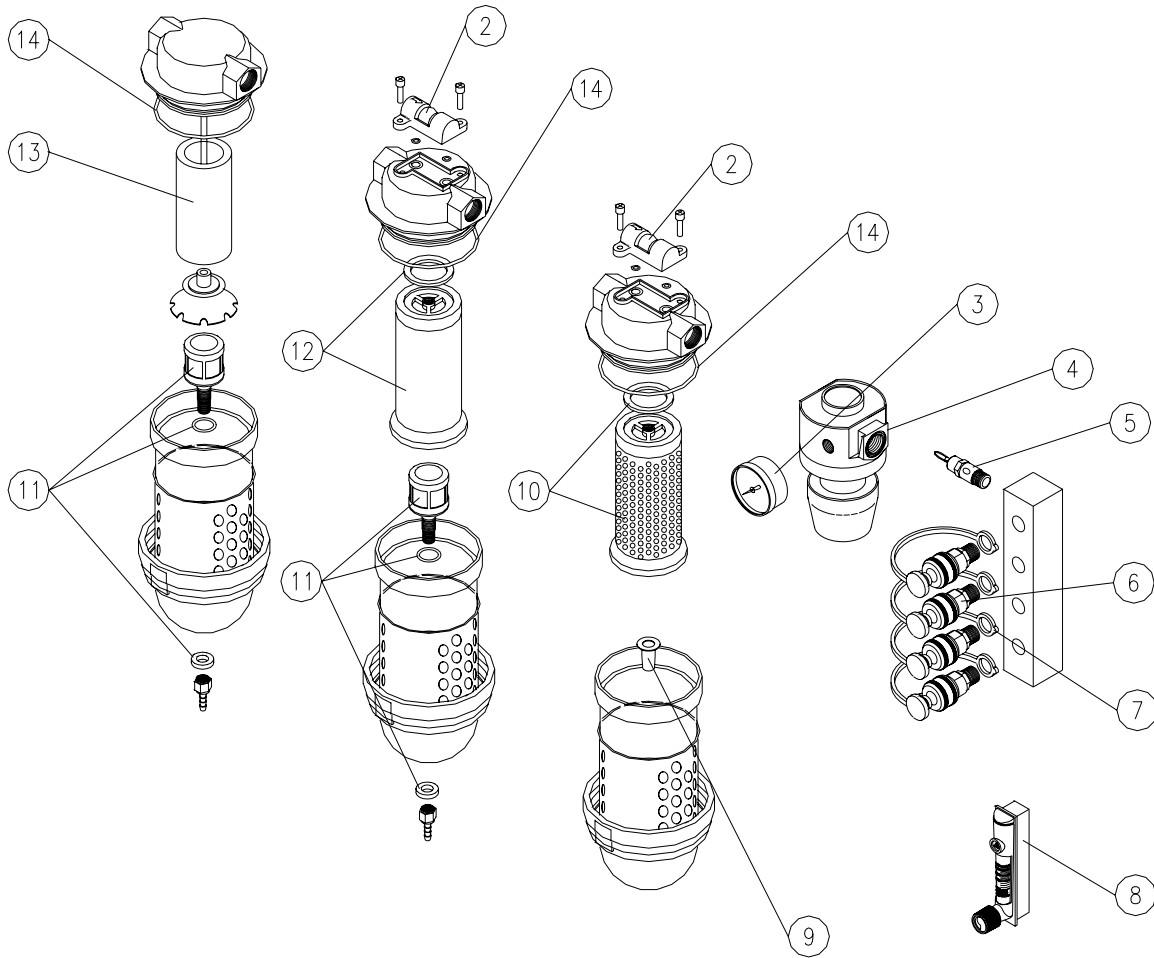

ITEM #	DESCRIPTION	100 CFM
1	INLET FITTING	QDH5PL8M
2	FILTER CHANGE INDICATOR	WL056
3	PRESSURE GAUGE	GA20160B
4	PRESSURE REGULATOR	WL015
5	RELIEF VALVE, 125 PSI	VR4125BR
6	HANSEN COUPLING	QDH3SL6M
6A	SCHRADER COUPLING	QDSSL6M
7	HANSEN DUST CAP	QDH3DCAP
7A	SCHRADER DUST CAP	QDSDCAP
8	FLOWMETER	WL033NS
9	MANUAL DRAIN	WL153
10	"D" FILTER ELEMENT	BB100-D
11	AUTO DRAIN ASSEMBLY	WL024
12	"C" FILTER ELEMENT	BB100-C
13	"A" FILTER ELEMENT	BB100-A
14	FILTER BOWL O-RING	WL113

PLASTIC BOWL PART #WL055(NOT SHOWN)

MODEL BB150-COPM REPLACEMENT FILTER BREAKDOWN

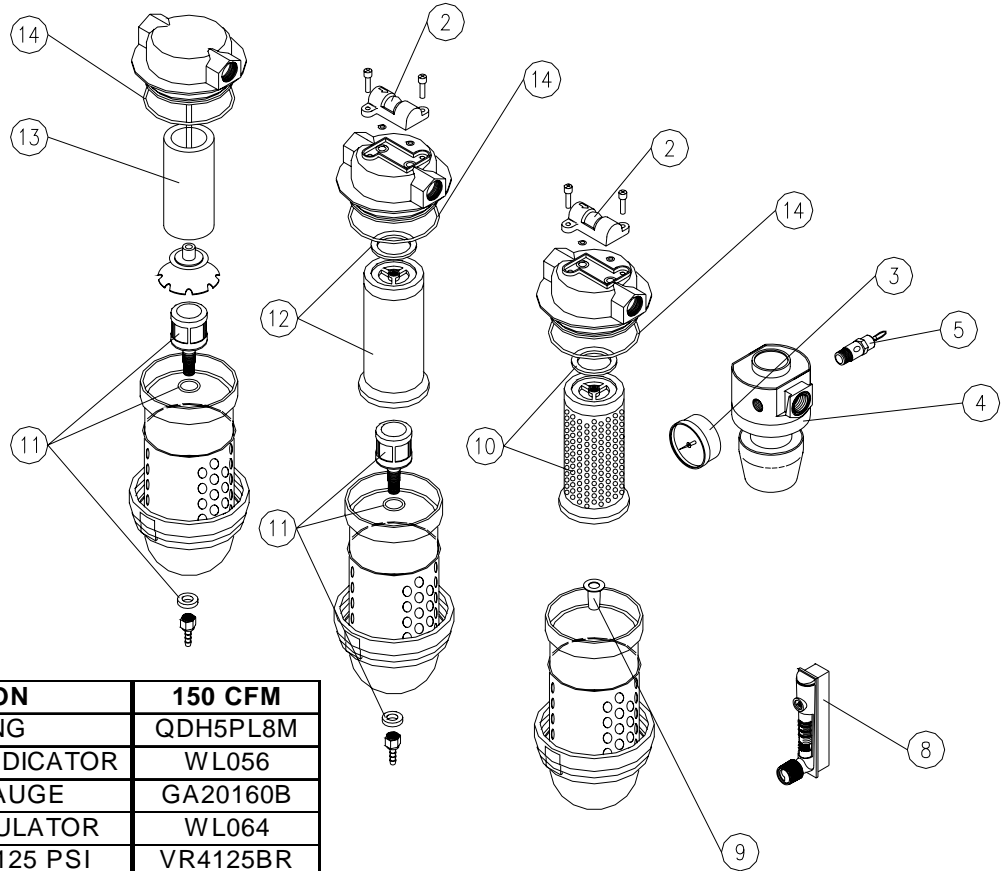

PLASTIC BOWL PART #WL055(NOT SHOWN)

ITEM #	DESCRIPTION	150 CFM
1	INLET FITTING	QDH5PL8M
2	FILTER CHANGE INDICATOR	WL056
3	PRESSURE GAUGE	GA20160B
4	PRESSURE REGULATOR	WL064
5	RELIEF VALVE, 125 PSI	VR4125BR
6	HANSEN COUPLING	N/A
6A	SCHRADER COUPLING	N/A
7	HANSEN DUST CAP	N/A
7A	SCHRADER DUST CAP	N/A
8	FLOWMETER	WL033NS
9	MANUAL DRAIN	WL153
10	"D" FILTER ELEMENT	BB150-D
11	AUTO DRAIN ASSEMBLY	WL024
12	"C" FILTER ELEMENT	BB150-C
13	"A" FILTER ELEMENT	BB150-A
14	FILTER BOWL O-RING	WL113

Warranty Disclaimer

Air Systems' manufactured equipment is warranted to the original user against defects in workmanship or materials under normal use for one year after date of purchase. Any part which is determined by Air Systems to be defective in material or workmanship will be, as the exclusive remedy, repaired or replaced at Air Systems' option. This warranty does not apply to electrical systems or electronic components. Electrical parts are warranted, to the original user, for 90 days from the date of sale. During the warranty period, electrical components will be repaired or replaced at Air Systems' option.

NO OTHER WARRANTY, EXPRESSED OR IMPLIED, AS TO DESCRIPTION, QUALITY, MERCHANTABILITY, FITNESS FOR A PARTICULAR PURPOSE, OR ANY OTHER MATTER IS GIVEN BY AIR SYSTEMS IN CONNECTION HERewith. UNDER NO CIRCUMSTANCES SHALL THE SELLER BE LIABLE FOR LOSS OF PROFITS, ANY OTHER DIRECT OR INDIRECT COSTS, EXPENSES, LOSSES OR DAMAGES ARISING OUT OF DEFECTS IN, OR FAILURE OF THE PRODUCT OR ANY PART THEREOF.

The purchaser shall be solely responsible for compliance with all applicable Federal, State and Local OSHA and/or MSHA requirements. Although Air Systems International believes that its products, if operated and maintained as shipped from the factory and in accordance with our "operations manual", conform to OSHA and/or MSHA requirements, there are no implied or expressed warranties of such compliance extending beyond the limited warranty described herein. Product designs and specifications are subject to change without notice.

Rev 2 12/98

Air leaks are not covered under warranty except when they result from a defective system component, i.e. an on/off valve or regulator or upon initial delivery due to poor workmanship. Air leaks due to poor delivery or damage will be covered under delivery claims. Minor air leaks are part of routine service and maintenance and are the responsibility of the customer just as are filters and oil changes.